

A Pixel Telescope for Detector R&D for an International Linear Collider

Tobias Haas¹

Deutsches Elektronensynchrotron, D-22603 Hamburg, Germany

Abstract

A beam telescope based on monolithic active pixel technology will be developed within the EUDET collaboration, a coordinated detector R&D programme for a future international linear collider. The telescope will consist of up to six sensor planes. The telescope can be operated inside a solenoidal magnetic field of up to 1.2 T. In addition, a general purpose cooling, positioning and readout infrastructure will be available. The telescope and the magnet will initially be installed at a 6 GeV/c electron beam line at DESY. However, the setup will be sufficiently flexible to be moved to higher energy hadron beam lines, for instance at CERN, in the future. Thus the telescope will provide a test environment for a wide variety of pixel-lated sensor technologies, while at the same time acting as a realistic test bed for tracking studies for a vertex detector at a future linear collider.

Key words: Linear Collider, Vertex Detector, Pixel Sensor

PACS: 13.66.Jn, 07.77.Ka, 29.40.Wk

1. Introduction

A 500 GeV electron-positron linear collider is the next great international project in High Energy Physics. While it is very likely that new physics will be found at the LHC at CERN, the interpretation of the observed phenomena will be difficult at best within the complicated environment of a hadron machine. This is due both to large backgrounds as well as limited experimental precision of the LHC detectors. Only the much cleaner environment in electron-positron collisions coupled with an extremely precise detector will permit to interpret these discoveries. Thus, if electro-weak

symmetry breaking is to be understood within the next fifteen to twenty years, concurrent operation of the linear collider with the LHC is mandatory. This means that the machine would have to be approved in 2010 and possibly commence operation around 2015.

On the way to achieve that goal an intense international planning effort together with a number of R&D projects have started up. EUDET [1] is one project within that context. It does not directly aim at detector R&D. Instead it will improve the infrastructure for doing detector R&D for the future international linear collider. EUDET is partially funded by the European union as a so-called “Integrated Infrastructure Initiative” within its 6th Framework Programme for Research and

¹ For the EUDET Collaboration

Technological Development [2]. The total budget of EUDET amounts to 21.5 Million Euros out of which 7 Million Euros are funded by the European Union.

EUDET covers a number of different activities relating to tracking, calorimetry and pixel R&D as well as so-called networking activities which support information exchange. In this paper we shall discuss only one activity, namely the construction of a pixel beam telescope to be operated initially at the DESY-II 6 GeV/c electron test beam facility. This paper is structured as follows: After a brief description of the DESY-II test beam facility the plans for the different aspects of the beam telescope are described. These are the pixel sensors, the layout, mechanics and cooling and finally the DAQ system. We conclude with a summary and outlook which covers a number of foreseen uses of the facility in the future.

2. The DESY-II 6 GeV/c electron test beam facility

The DESY-II beam-test [3] provides a parasitic electron beam after two conversions of the 7 GeV/c beam of the electron/positron synchrotron DESY-II. A bremsstrahlung beam is produced by a 10 μm thick carbon fiber target which intercepts the primary beam. The generated photons are converted by a copper or aluminum target into electron-positron pairs, and the particle momentum can be selected by setting the current of a bending magnet, which finally delivers the beam through a collimator slit into the experimental hall. The maximum momentum achievable for electrons or positrons is around 7 GeV/c. The particle rates available vary strongly with energy. They are summarized in table 1.

3. Telescope requirements

The beam telescope is to be used for a wide range of R&D applications and quite different devices under test (DUT), from small (a few millimeters) to large (up to one meter) sizes. Depending on the

Rates	Target	
	3 mm Cu	1 mm Cu
1 GeV/c	330 Hz	220 Hz
2 GeV/c	500 Hz	330 Hz
3 GeV/c	1000 Hz	660 Hz
5 GeV/c	500 Hz	330 Hz
6 GeV/c	250 Hz	160 Hz

Table 1
Energies and rates available ($1/\text{cm}^{-2}$) at the DESY-II test beam facility.

project and on the size of the device the requirements as to precision and coverage are quite different. Still, the system should be easy to use so that a high efficiency in the use of the facility can be achieved.

The DESY-II test beam environment poses serious limitations on precision measurements due to multiple scattering. For that reason it is mandatory to minimize the number of sensor planes and to reduce the amount of material in individual planes while maintaining point precision on the telescope planes of around 2 – 3 μm . The mechanical setup should allow for a wide range of different configurations from a very compact one useful for pixel sensors to a two-arm layout with sufficient space in between arms to accommodate TPC or calorimeter prototypes. The lateral dimensions of the active area should be large enough to cover high precision pixel devices without mechanical movement of the device under test. Obviously, for larger devices mechanical actuators will have to be used. A minimum size of 20 mm in one lateral dimension is adequate. The second dimension could possibly be smaller. The speed of the device should allow to take full advantage of the beam rates and hence should be able to operate at readout frequencies of up to 1 kHz.

Finally, the overall setup of the telescope should be flexible enough to make it transportable in order to use it at other beam lines outside of DESY, e. g. at higher energy hadron beam lines.

4. Sensors

As discussed in the previous section the sensors for the telescope have to provide a single point resolution of $2 - 3\mu\text{m}$ with a minimum of material. Also, a reasonable lateral coverage is required and the readout has to be fast enough to reach a telescope readout speed of 1 kHz.

R&D towards an ILC vertex detector is actively being pursued on a number of different sensor technologies such as CCDs [5], DEPFETs [6] and CMOS [7] sensors and a number of prototypes emphasizing different aspects of these devices have been built. Most of these prototypes are too small for the planned telescope. However, the CNRS-IRES institute in Strasbourg, France [8] has also successfully developed, fabricated and tested the MIMOSA-5 chip, which is a larger device with dimensions $20 \times 20 \text{ mm}^2$ and about 1 million pixels. Fig. 1 demonstrates the signal-to-noise ratio of the MIMOSA-5 chip measured in the DESY-II 6 GeV/c testbeam. While MIMOSA-5 shows a good signal-to-noise ratio and high point precision, its architecture is simple without integrated data reduction or parallelization. Therefore a minimum of 256k pixels have to be read out twice in a completely serial fashion in order to obtain a single event. This results in a 25 ms frame readout time or a maximum data rate of 20 Hz at 10 MHz clock frequency, far from the 1 kHz requirement.

Therefore, while a chip derived from the MIMOSA-5 technology was chosen as the baseline for the first iteration of the pixel telescope it is also obvious that additional sensor R&D is needed to completely fulfill the telescope requirements for the final telescope.

5. Layout, mechanics and cooling

It is foreseen that the beam telescope will be operated in widely varying R&D applications with very different DUTs. Four telescope parameters are particularly relevant in this context. These are the number of measurement planes, the active area, longitudinal size and layout of the telescope, the mechanical support for the DUT and the envi-

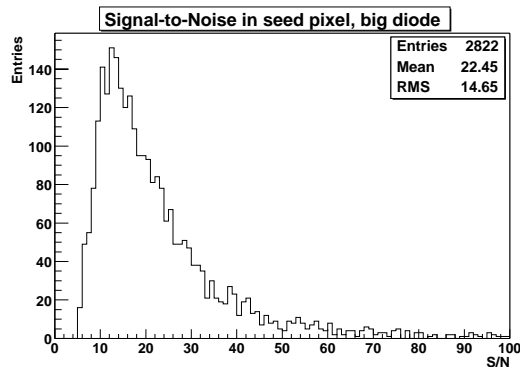

Fig. 1. Signal-to-noise distribution for 6 GeV/c electrons for an individual seed pixel in a MIMOSA-5 CMOS sensor operated at -10° C .

ronmental conditions such as gas flow and temperature. It is planned to provide up to 6 telescope planes for redundancy and flexibility. For large DUTs mechanical actuation is foreseen in order to move the device through the active area of the telescope. Fig. 2 shows three foreseen layouts for the pixel telescope. Version (a) is very compact and will typically be used for characterizing high precision devices. In this configuration one of the telescope planes should be built such that it can be moved very close to the pixel DUT in order to limit the effects of multiple scattering. Layout (b) inside a 1.2 T superconducting solenoid can be used for internal tracking. In this configuration the telescope acts as a small slice of a future vertex detector. Finally, layout (c) will be used with large devices such as TPC and calorimeter prototypes.

6. DAQ system

A schematic of the planned DAQ system is shown in Fig. 3. It consists of a frontend board that handles signal conditioning, sequencing and digitization. From the frontend board the data are transferred to the data reduction board. Using an FPGA processor this board handles common mode suppression and data sparsification. The sparsified data will then be transferred either over a VME bus or over a USB-2 interface into a PC for event building and archiving. Communication

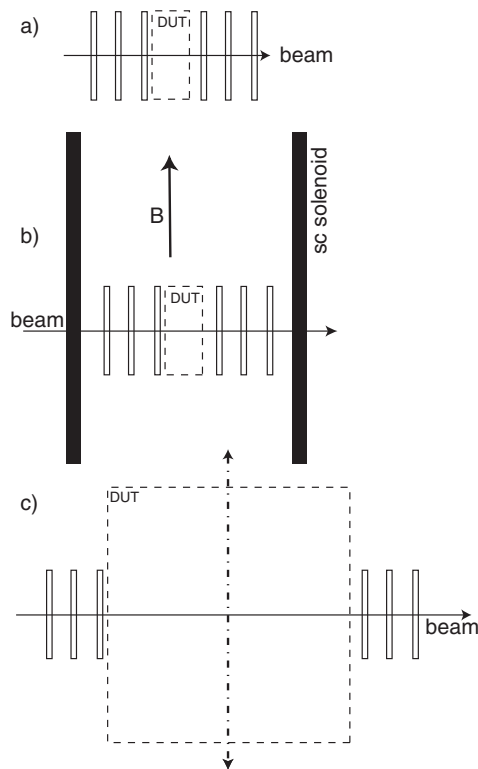

Fig. 2. Three foreseen layouts for the beam telescope; (a) a compact layout for characterization of high precision devices, (b) a compact layout inside a magnetic field and (c) a two-arm geometry for the use with larger DUTs.

with the DUT is over the trigger and busy lines only and synchronization will occur via a unique event number. The interface to the DUT is intentionally kept very simple in order to easily and quickly accommodate the widest possible range of devices.

7. Summary and outlook

We have presented the plans for the construction of a fast high precision beam telescope within the framework of the EUDET initiative for improving the R&D infrastructure for a future ILC detector in Europe. This project is currently getting under way and a demonstrator telescope will be available in the middle of 2007. The final telescope reaching the full specifications will be available at the

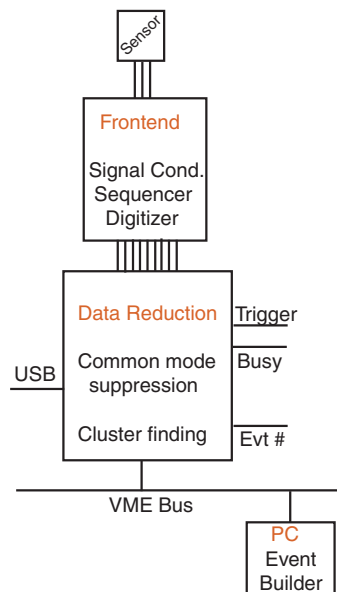

Fig. 3. Schematic layout of the DAQ system.

end of 2008. Thus a highly flexible facility reaching excellent precision and allowing high data rates in different test beam environments will be available to the community doing ILC detector R&D.

References

- [1] <http://www.eudet.org>
- [2] <http://europa.eu.int/comm/research/fp6>
- [3] D. Autiero, P. Migliozi et al.; OPERA Collaboration; "Characterization of the T24 electron beam line available at DESY", March 12, 2004
- [4] D. Contarato et al., "Beam-test of CMOS pixel sensors with 6 GeV/c electrons", Proc. Conf. Pixel 2005, to be publ.
- [5] C.J.S. Damerell, "CCD Vertex Detectors in Particle Physics", Nucl. Instrum. Meth. A **342** (1994) 78.
- [6] P. Fischer, W. Neeser, M. Trimpl, J. Ulrici, N. Wermes, "Readout concepts for DEPFET pixel arrays", Nucl. Instrum. Meth. A **512** (2003) 318.
- [7] R. Turchetta et al., "A monolithic active pixel sensor for charged particle tracking and imaging using standard VLSI CMOS technology", Nucl. Instrum. Meth. A **458** (2001) 677.
- [8] Y. Gornushkin et al., "Tracking performance and radiation tolerance of monolithic active pixel sensors", Nucl. Instrum. Meth. A **512** (2003) 299.